

CBSE Board
Class XII Physics – Set 1
Board Paper - 2013

Time: 3 hours

Total Marks: 70

General Instructions:

1. All questions are compulsory.
2. There are 29 questions in total. Question Nos. 1 to 8 are very short answer type questions and carry one mark each.
3. Question Nos. 9 to 16 carry two marks each, Question Nos. 17 to 25 carry three marks each and Question Nos. 27 to 29 carry five marks each.
4. There is no overall choice. However, an internal choice has been provided in one question of two marks, one question of three marks and all three questions of five marks each. You have to attempt only one of the choices in such questions.
5. Question No. 26 is value based questions carry four marks.
6. Use of calculators is not permitted. However, you may use log tables if necessary.
7. You may use the following values of physical constants wherever necessary:

$$c = 3 \times 10^8 \text{ m/s}$$

$$h = 6.63 \times 10^{-34} \text{ Js}$$

$$e = 1.6 \times 10^{-19} \text{ C}$$

$$\mu_0 = 4\pi \times 10^{-7} \text{ TmA}^{-1}$$

$$\frac{1}{4\pi\epsilon_0} = 9 \times 10^9 \text{ Nm}^2\text{C}^{-2}$$

$$m_e = 9.1 \times 10^{-31} \text{ kg}$$

$$\text{Mass of the Neutron} = 1.675 \times 10^{-27} \text{ kg}$$

$$\text{Mass of the Proton} = 1.673 \times 10^{-27} \text{ kg}$$

1. What is the geometrical shape of equipotential surfaces due to a single isolated charge?
2. Write the relationship between angle of incidence 'i', angle of prism 'A' and angle of minimum deviation for a triangular prism.
3. A capacitor has been charged by a dc source. What are the magnitudes of conduction and displacement currents, when it is fully charged?

4. The given graph shows the variation of photo-electric current (I) versus applied voltage (V) for two different photosensitive materials and for two different intensities of the incident radiation. Identify the pairs of curves that correspond to different materials but same intensity of incident radiation.

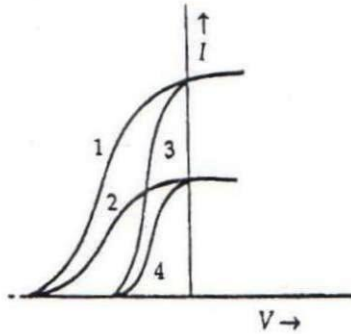

5. Which of the following waves can be polarized (i) Heat waves (ii) Sound waves? Give reason to support your answer.
6. A 5 V battery of negligible internal resistance is connected across a 200 V battery and a resistance of 39Ω as shown in the figure. Find the value of the current.

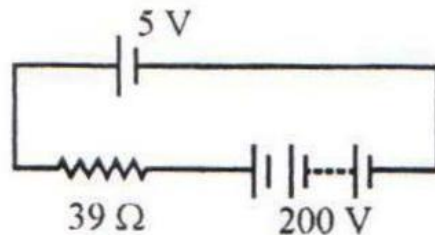

7. Which of the following substances are para-magnetic?
Bi, Al, Cu, Ca, Pb, Ni
8. A heating element is marked 210 V, 630 W. Find the resistance of the element when connected to a 210 V dc source.
9. An ammeter of resistance 0.6Ω can measure current up to 1.0 A. Calculate (i) The shunt resistance required to enable the ammeter to measure current up to 5.0 A (ii) The combined resistance of the ammeter and the shunt.
10. (a) Write the necessary conditions for the phenomenon of total internal reflection to occur.
(b) Write the relation between the refractive index and critical angle for a given pair of optical media.

11. (a) An em wave is travelling in a medium with a velocity $\vec{v} = v\hat{i}$. Draw a sketch showing the propagation of the em wave, indicating the direction of the oscillating electric and magnetic fields.
 (b) How are the magnitudes of the electric and magnetic fields related to the velocity of the em wave?

12.

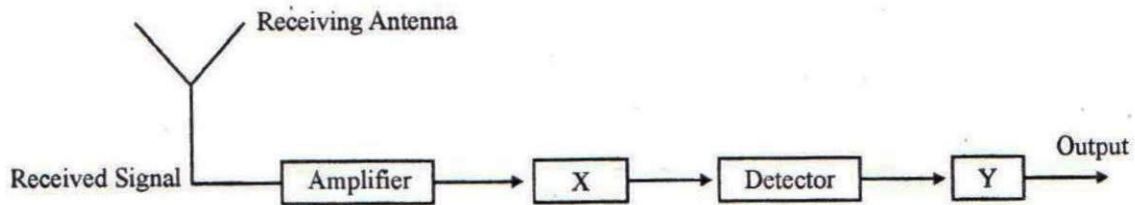

- (a) Identify 'X' and 'Y'
 (b) Write their functions.

13. State Lenz's Law.

A metallic rod held horizontally along east-west direction, is allowed to fall under gravity. Will there be an e.m.f. induced at its ends? Justify your answer.

14. Explain, with the help of a circuit diagram, the working to a photo-diode. Write briefly how it is used to detect the optical signals.

OR

Mention the important considerations required while fabricating a p-n junction diode to be used as a Light Emitting Diode (LED). What should be the order of band gap of an LED if it is required to emit light in the visible range?

15. A convex lens of focal length 30 cm is placed coaxially in contact with a concave lens of focal length 40 cm. Determine the power of the combination. Will the system be converging or diverging in nature?

16. In the given circuit diagram, a voltmeter 'V' is connected across a lamp 'L'. How would (i) the brightness of the lamp and (ii) voltmeter reading 'V' be affected, if the value of resistance 'R' is decreased? Justify your answer.

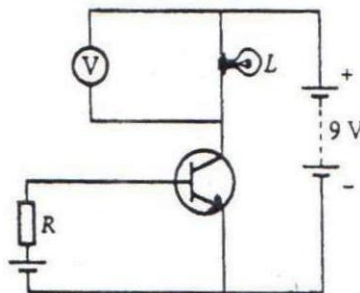

17. A metallic rod of length ' l ' is rotated with a frequency ν with one end hinged at the centre and the other end at the circumference of a circular metallic ring of radius l , about an axis passing through the centre and perpendicular to the plane of the ring. A constant uniform magnetic field B parallel to the axis is present everywhere. Using Lorentz force, explain how e.m.f. is induced between the centre and the metallic ring and hence obtain the expression for it.
18. A capacitor of unknown capacitance is connected across a battery of V volts. The charge stored in it is $300 \mu\text{C}$. When potential across the capacitor is reduced by 100 V , the charge stored in it becomes $100 \mu\text{C}$. Calculate the potential V and the unknown capacitance. What will be the charge stored in the capacitor if the voltage applied had increased by 100 V ?

Or

A hollow cylindrical box of length 0.5 m and area of cross-section 20 cm^2 is placed in a three dimensional coordinate system as shown in the figure. The electric field in the region is given by $\vec{E} = 20x \hat{i}$, where E is NC^{-1} and x is in metres. Find

- (i) Net flux through the cylinder.
(ii) Charge enclosed in the cylinder.

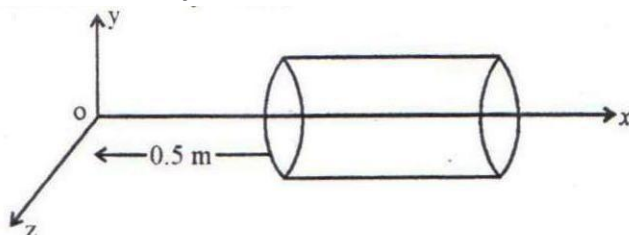

19. (a) Write two characteristic features distinguishing the diffraction pattern from the interference fringes obtained in Young's double slit experiment.
(b) Two wavelengths of sodium light 590 nm are used, in turn, to study the diffraction taking place due to a single slit of aperture $1 \times 10^{-4} \text{ m}$. The distance between the slit and the screen is 1.8 m . Calculate the separation between the positions of the first maxima of the diffraction pattern obtained in the two cases.
20. Write three important factors which justify the need of modulating a message signal. Show diagrammatically how an amplitude modulated wave is obtained when a modulating signal is superimposed on carrier wave.
21. (a) In a nuclear reaction
 ${}^3_2\text{He} + {}^3_2\text{He} \longrightarrow {}^4_2\text{He} + {}^1_1\text{H} + 12.86\text{MeV}$, through the number of nucleons is conserved on both sides of the reaction, yet the energy is released. How? Explain.
(b) Draw a plot of potential energy between a pair of nucleons as a function of their separation. Mark the regions where potential energy is (i) positive and (ii) negative.

22. (a) Why photoelectric effect cannot be explained on the basis of wave nature of light? Give reasons.
 (b) Write the basic features of photon picture of electromagnetic radiation on which Einstein's photoelectric equation is based.
23. Output characteristics of an n-p-n transistor in CE configuration is shown in the figure. Determine:
 (i) dynamic output resistance
 (ii) dc current gain and
 (iii) ac current gain at an operating point $V_{CE} = 10\text{ V}$, when $I_B = 30\ \mu\text{A}$.

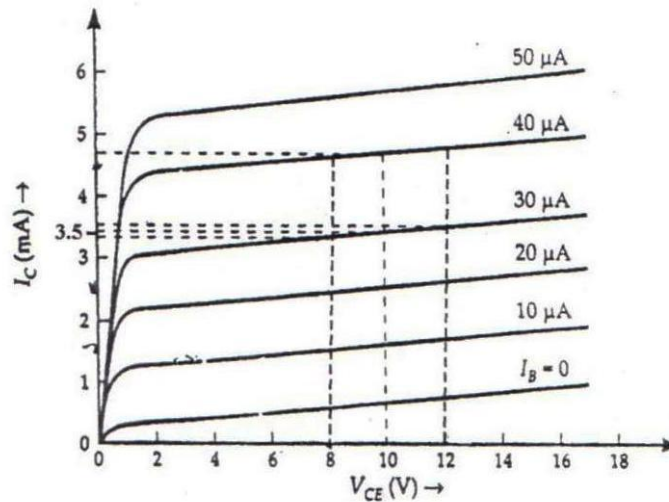

24. In a series LCR circuit connected to an ac source of variable frequency and voltage $v = v_m \sin \omega t$, draw a plot showing the variation of current (I) with angular frequency (ω) for two different values of resistance R_1 and R_2 ($R_1 > R_2$). Write the condition under which the phenomenon of resonance occurs. For which value of the resistance out of the two curves a sharper resonance is produced? Define Q-factor of the circuit and give its significance.
25. (a) Using Bohr's postulates, obtain the expression for total energy of the electron in the n^{th} orbit of hydrogen atom.
 (b) What is the significance of negative sign in the expression for the energy?
 (c) Draw the energy level diagram showing how the line spectra corresponding to Paschen series occur due to transition between energy levels.
26. While travelling back to his residence in the car, Dr. Pathak was caught up in a thunderstorm. It became very dark. He stopped driving the car and waited for thunderstorm to stop? Suddenly he noticed a child walking alone on the road. He asked the boy to come inside the car till the thunderstorm stopped. Dr. Pathak dropped the boy at his residence. The boy insisted that Dr. Pathak should meet his parents. The parents expressed their gratitude to Dr. Pathak for his concern for safety of the child.

Answer the following questions based on the above information:

- (a) Why is it safer to sit inside a car during a thunderstorm?
- (b) Which two values are displayed by Dr. Pathak in his actions?
- (c) Which values are reflected in parents' response to Dr. Pathak?
- (d) Give an example of a similar action on your part in the past from everyday life.

27. (a) Derive the expression for the torque on a rectangular current carrying loop suspended in a uniform magnetic field.
- (b) A proton and a deuteron having equal momenta enter in a region of uniform magnetic field at right angle to the direction of the field. Depict their trajectories in the field.

OR

- (a) A small compass needle of magnetic moment 'm' is free to turn about an axis perpendicular to the direction of uniform magnetic field 'B'. The moment of inertia of the needle about the axis is 'I'. The needle is slightly disturbed from its stable position and then released. Prove that it executes simple harmonic motion. Hence deduce the expression for its time period.
- (b) A compass needle, free to turn in a vertical plane orients itself with its axis vertical at a certain place on the earth. Find out the values of (i) horizontal component of earth's magnetic field and (ii) angle of dip at the place.

28. (a) Draw a ray diagram showing the image formation by a compound microscope. Hence obtain expression for total magnification when the image is formed at infinity.
- (b) Distinguish between myopia and hypermetropia. Show diagrammatically how these defects can be corrected.

OR

- (a) State Huygen's principle. Using this principle draw a diagram to show how a plane wave front incident at the interface of the two media gets refracted when it propagates from a rarer to a denser medium. Hence verify Snell's law of refraction.
- (b) When monochromatic light travels from a rarer to a denser medium, explain the following, giving reasons:
- (i) Is the frequency of reflected and refracted light same as the frequency of incident light?
 - (ii) Does the decrease in speed imply a reduction in the energy carried by light wave?

29. (a) State the working principle of a potentiometer. With the help of the circuit diagram, explain how a potentiometer is used to compare the e.m.f.'s of two primary cells. Obtain the required expression used for comparing the e.m.f.'s.
- (b) Write two possible causes for one sided deflection in a potentiometer experiment.

OR

(a) State Kirchhoff's rules for an electric network. Using Kirchhoff's rules, obtain the balance condition in terms of the resistances of four arms of Wheatstone bridge.

(b) In the meterbridge experimental set up, shown in the figure, the null point 'D' is obtained at a distance of 40 cm from end A of the meterbridge. If a resistance of $10\ \Omega$ is connected in series with R_1 , null point is obtained at $AD = 60$ cm. Calculate the values of R_1 and R_2 .

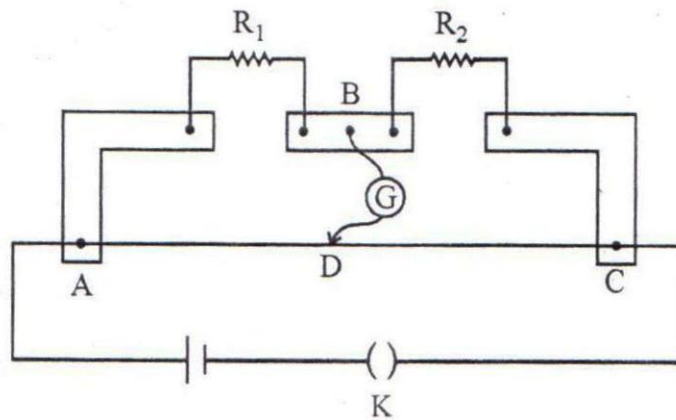

CBSE Board
Class XII Physics – Set 1
Board Paper – 2013 (Solution)

1. The equipotential surfaces due to a single isolated charge are concentric spherical surfaces. As the distance from the charge increases the electric field strength will decrease and the distance between the spherical surfaces will increase.

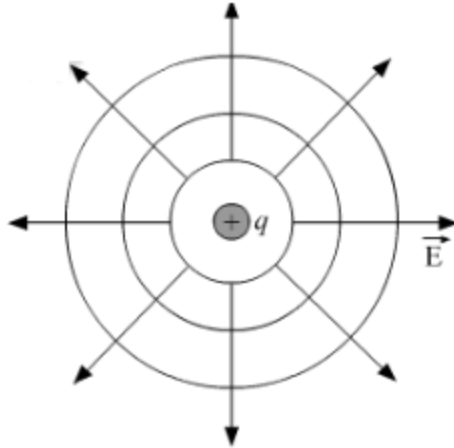

2. The relation between the angle of incidence i , angle of prism A and angle of minimum deviation is:
Angle of minimum deviation $= \delta_m = 2i - A$
3. Electric flux through the plates of the capacitor $= \phi = \frac{q}{\epsilon_0}$
As q is constant after the capacitor is fully charged, ϕ will also be a constant.
So displacement current $I_d = \epsilon_0 \frac{d\phi}{dt} = 0$
Conduction current $= I_c = C \frac{dV}{dt} = 0$ as V is constant.
 $I_c = I_d$ when the capacitor will be fully charged.
4. Curve 1 and 3 and curves 2 and 4 corresponds to different materials.
For a given frequency of incident radiation the stopping potential is independent of intensity of light. As the pair of curves: 1 & 3 and 2 & 4 have different stopping potential so those materials are different.

5. (i) Heat waves can be polarized as it is transverse wave and propagates in perpendicular direction to the direction of vibration / disturbance in individual particle
(ii) Sound waves cannot be polarized as it is longitudinal wave. In longitudinal wave the disturbance/oscillation in individual particle take place in the direction of propagation of wave.

6. Value of current in the circuit:
Applying Kirchoff's loop rule, we get

$$I \times 39 = 200 - 5 = 195$$

$$I = 5 \text{ A}$$

7. Al and Ca

8. $V = 210 \text{ V}$
 $P = 630 \text{ W}$
 $R = ?$

$$R = \frac{V^2}{P} = \frac{210 \times 210}{630} = 70 \Omega$$

9. $R = 0.6 \Omega$

$$I_{\max} = 1.0 \text{ A}$$

Shunt resistance = R_s so that the ammeter can measure up to 5.0 A.

For this the voltage difference across the ammeter when allowing max current = voltage difference across the (shunt + ammeter) allowing max 5.0 A current

$$1 \times 0.6 = \frac{R_s \times 0.6}{R_s + 0.6} \times 5$$

Solving the above expression: $R_s = 0.15 \Omega$

Shunt resistance = 0.15Ω

The combined resistance of the ammeter and the shunt = $\frac{0.15 \times 0.6}{0.15 + 0.6} = 0.12 \Omega$

- 10.

(a) Necessary conditions for total internal reflection to occur are:

- (i) The incident ray on the interface should travel in optically denser medium.
(ii) The angle of incidence should be greater than the critical angle for the given pair of optical media.

(b) ${}^a\mu_b = \frac{1}{\sin C}$, where, a and b are the rarer and denser media respectively. C is the critical angle for the given pair of optical media.

11. (a) Magnetic field will be along Z- axis and electric field along Y- axis.
The sketch of the em wave indicating the direction of electric and magnetic field will be:

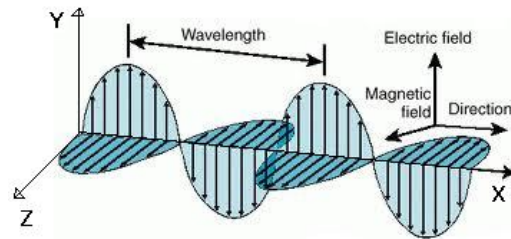

(b) $E = c \times B$

Where E is magnitude of electric field and B is magnitude of magnetic field, c= speed of light.

12. (a) X represents Intermediate Frequency (IF) stage while Y represents an Amplifier.
(b) At IF stage, the carrier frequency is changed to a lower frequency and in this process, the modulated signal is detected. While the function of amplifier is to amplify the detected signal which may not be strong enough to be made use of and hence is required.

13. Lenz's law states that the polarity of induced e.m.f. is such that it opposes the change in magnetic flux which caused it to produce.
Yes, there will be an e.m.f. induced due to changing magnitude of earth's magnetic field.

14.

Photodiode is a special type of photo-detector. The general principle is electronic excitation from the valence band to conduction band by photons. If an optical photon of frequency ν is incident on a semiconductor, such that its energy is greater than the band gap of the semiconductor, it will excite an electron from the valence band to the conduction band, leaving a vacancy or hole in the valence band. Thus, an electron-hole pair will be created. These are called 'photo generated charge carriers' which increase the conductivity of the semiconductor.

It can detect optical signals:

Working:

Larger the intensity of incident light, larger will be the change in conductivity of the semiconductor. Therefore, by measuring the change in the resistance of the semiconductor, one can measure the intensity of the optical signal. The simplest photodiode is a reverse-biased p-n junction diode. If such a p-n diode is illuminated with light photons having energy $h\nu > E_g$, and different intensities I_1, I_2, I_3 etc., the electron and hole pairs generated in the depletion layer or near the junction will be separated by the junction field and made to flow across the junction. There would be a change in the reverse saturation current, measuring which on illumination, can give the values of the light intensity.

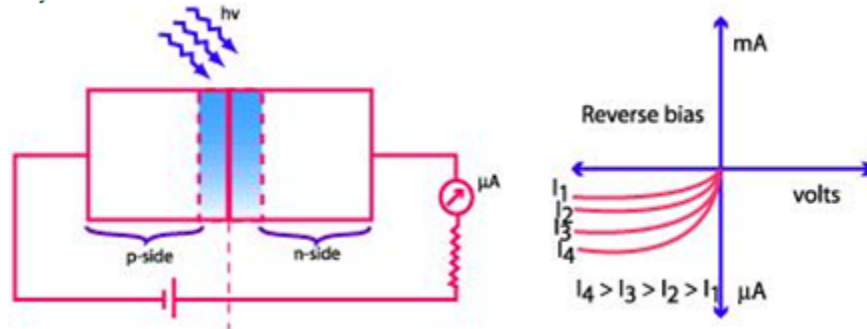

OR

Considerations:

1. The reverse breakdown voltages of LEDs are very low, typically around 5V. So care should be taken while fabricating a pn-junction diode so that the high reverse voltages do not appear across them.
2. There is very little resistance to limit the current in LED. Therefore, a resistor must be used in series with the LED to avoid any damage to it.

This emission is due to transitions between semiconductor energy states, when an electron falls from a higher state into lower energy states containing holes. The energy of radiation emitted is less than the band gap of the semiconductor used.

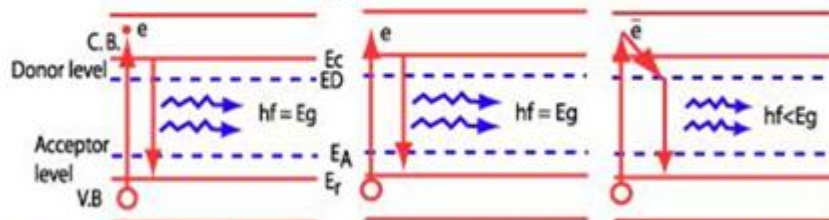

The semiconductor used in LED is chosen according to the required wavelength of emitted radiation.

The semiconductor used for fabrication of visible LEDs must at least have a band gap of 1.8 eV (spectral range of visible light is from about $0.4 \mu m$ to $0.7 \mu m$, i.e., from about 3 eV to 1.8 eV).

15.

Focal length of convex lens, $f_1 = +30$ cm

Focal length of concave lens, $f_2 = -40$ cm

$$\text{Equivalent focal length, } \frac{1}{F} = \frac{1}{f_1} + \frac{1}{f_2} = \frac{1}{30} + \frac{1}{-40} = \frac{4-3}{120} = \frac{1}{120}$$

$$F = 120 \text{ cm} = 1.2 \text{ m}$$

$$\text{Power of the combination, } P = \frac{1}{F} = \frac{1}{1.2} = 0.83 \text{ D}$$

As the power of the combination is positive, system will be converging in nature.

16.

As the base resistance R decreases, the input circuit will become more forward biased thus decreasing the base current (I_B) and increasing the emitter current (I_E). This will increase the collector current (I_C) as $I_E = I_B + I_C$.

When I_C increases which flows through the lamp, the voltage across the bulb will also increase thus making the lamp brighter and as the voltmeter is connected in parallel with the lamp, the reading in the voltmeter will also increase.

17.

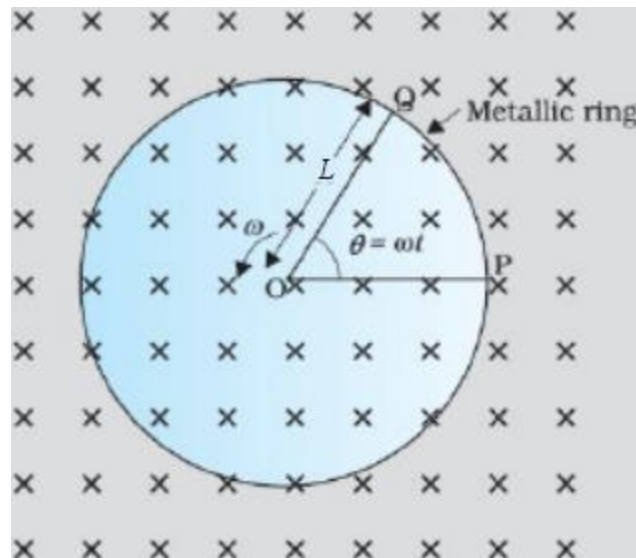

As the rod is rotated, free electrons in the rod move towards the outer end due to Lorentz force and get distributed over the ring. Thus, the resulting separation of charges produces an emf across the ends of the rod. At a certain value of emf, there is no more flow of electrons and a steady state is reached. The magnitude of the emf generated across a length dr of the rod as it moves at right angles to the magnetic field is given by

$$d\varepsilon = Bvdr$$

Hence,

$$\varepsilon = \int d\varepsilon = \int_0^l Bvdr = \int_0^l B\omega r dr = \frac{B\omega l^2}{2}$$

$$\varepsilon = \frac{B^2 \pi v l^2}{2} = B\pi v l^2$$

18.

We know :

$$Q = CV$$

in case 1 :

$$300 \times 10^{-6} = CV \dots \dots (i)$$

in case 2 :

$$100 \times 10^{-6} = C(V - 100) \dots \dots (ii)$$

from (i) & (ii) :

$$\frac{V}{300 \times 10^{-6}} = \frac{V - 100}{100 \times 10^{-6}}$$

$$V = 150 \text{ V}$$

$$C = \frac{300 \times 10^{-6}}{150} = 2 \times 10^{-6} \text{ F} = 2 \mu\text{F}$$

If voltage applied have increased by 100 V:

Charge stored will be=

$$Q = CV$$

in this case:

$$Q = 2 \times 10^{-6} \times 250$$

$$= 500 \times 10^{-6} \text{ C} = 500 \mu\text{C}$$

OR

$$\vec{E} = 20 \times \hat{i}$$

E_1 = at left circular face = $10 \hat{i}$...putting the value of x

E_2 = at right circular face = $20 \hat{i}$...putting the value of x

(i) net flux through the cylinder = $\int E \cdot ds = \int E_1 \cdot ds + \int E_2 \cdot ds + \int E \cdot ds$ (for curved surface)

$$= -10 \times \frac{20}{100 \times 100} + 20 \times \frac{20}{100 \times 100}$$

$$= 10 \times \frac{20}{100 \times 100} = 0.02 \text{ Nm}^2 \text{ C}^{-1}$$

(ii) charge enclosed in the cylinder (using Gauss's law) = $\frac{q}{\varepsilon_0} = 0.02$

$$q = 8.85 \times 10^{-12} \times 0.02 = 0.177 \times 10^{-12} \\ = 0.177 \times 10^{-12}$$

19.

- (a) If the width of each slit is comparable to the wavelength of light used, the interference pattern thus obtained in the double-slit experiment is modified by diffraction from each of the two slits.
- (b) Given that: Wavelength of the light beam, $\lambda_1 = 590 \text{ nm} = 5.9 \times 10^{-7} \text{ m}$

Wavelength of another light beam, $\lambda_2 = 596 \text{ nm} = 5.96 \times 10^{-7} \text{ m}$

Distance of the slits from the screen = $D = 1.8 \text{ m}$

Distance between the two slits = $a = 1 \times 10^{-4} \text{ m}$

For the first secondary maxima, $\sin \theta = \frac{3\lambda_1}{2a} = \frac{x_1}{D}$

Or

$$x_1 = \frac{3\lambda_1 D}{2a} \text{ and } x_2 = \frac{3\lambda_2 D}{2a}$$

\therefore Spacing between the positions of first secondary maxima of two sodium line

$$\begin{aligned} x_1 - x_2 &= \frac{3D}{2a} (\lambda_2 - \lambda_1) \\ &= 1.62 \times 10^{-5} \text{ m} \end{aligned}$$

20.

Three important factors which justify the need of modulating a message signal:

- (i) Size of antenna or aerial: For communication within the effective length of the antennas, the transmitting frequencies should be high, so modulation is required.
- (ii) Effective power which is radiated by antenna: Since the power radiated from a linear antenna is inversely proportional to the square of the transmitting wavelength. As high powers are needed for good transmission so higher frequency is required which can be achieved by modulation.
- (iii)

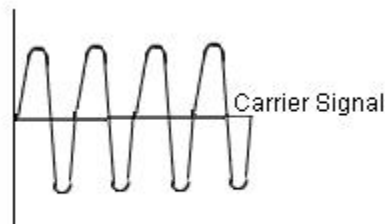

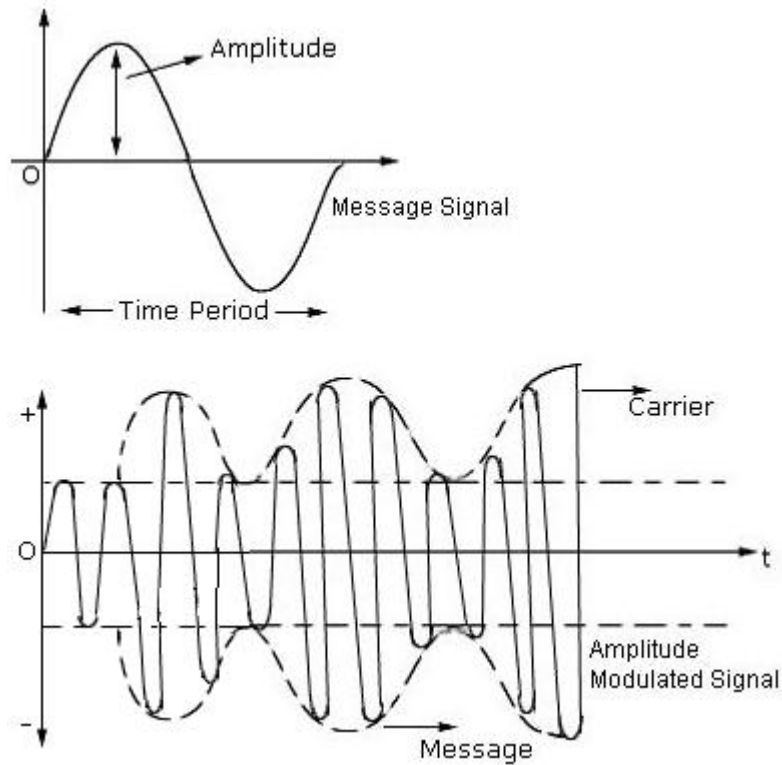

21. (a) This can be explained by the Q value concept of nuclear reaction:

$$Q = E(\text{Reactants}) - E(\text{Products})$$

$$Q = (m_n - m_p - m_{\bar{\nu}} - m_e)c^2$$

m_n is mass of neutron, m_p mass of proton, $m_{\bar{\nu}}$ mass of electron antineutrino, m_e mass of electron.

If this mass defect is calculated and the Q value is calculated from the above equation, then that value will be 12.86 MeV

(b)

Part AB represent repulsive force and part BCD represents attractive force .

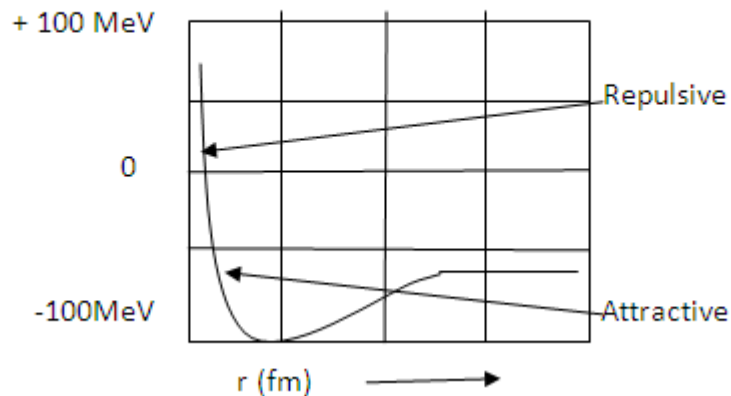

22.

- (a) Wave nature of radiation cannot explain the following:
- (i) The instantaneous ejection of photoelectrons.
 - (ii) The existence of threshold frequency for a metal surface.
 - (iii) The fact that kinetic energy of the emitted electrons is independent of the intensity of light and depends upon its frequency.

Thus, the photoelectric effect cannot be explained on the basis of wave nature of light.

(b) Photon picture of electromagnetic radiation on which Einstein's photoelectric equation is based on particle nature of light. Its basic features are:

- i. When interacting with matter radiation behaves like particles called photon.
- ii. Each photon has energy $E = h\nu$ and momentum $p = h\nu/c$ and $c =$ speed of light.
- iii. All photons of light of a particular frequency ν , wave length λ have same energy $E = h\nu = hc/\lambda$ and momentum $p = h\nu/c$ whatever is the intensity of radiation be.
- iv. By increasing the intensity of light of given wavelength, there is only an increase in the number of photons per second crossing a given area, with each photon having the same energy. So photon energy is independent of incident intensity.
- v. Photons are electrically neutral and are not deflected by electric and magnetic fields.
- vi. Photon particle collision is completely elastic in nature.

23.

- (i) Dynamic output resistance is given as:

$$R_o = \left(\frac{\Delta V_{CE}}{\Delta I_C} \right)_{I_B \text{ constant}} = \frac{12 - 8}{(3.6 - 3.4) \times 10^{-3}} = \frac{4}{0.2 \times 10^{-3}} = 20 \text{ k}\Omega$$

(ii) d.c current gain, $\beta_{dc} = \frac{I_C}{I_B} = \frac{3.5 \text{ mA}}{30 \mu\text{A}} = \frac{3.5 \times 10^{-3}}{30 \times 10^{-6}} = \frac{350}{3} = 116.67$

(iii) a.c current gain, $\beta_{ac} = \frac{\Delta I_C}{\Delta I_B} = \frac{(4.7 - 3.5) \text{ mA}}{(40 - 30) \mu\text{A}} = \frac{1.2 \times 10^{-3}}{10 \times 10^{-6}} = 120$

24.

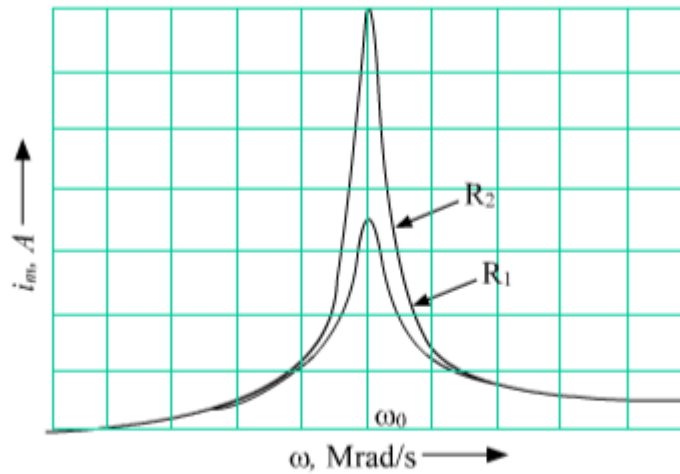

The condition for resonance in the LCR circuit is,

$$\omega_0 = \frac{1}{\sqrt{LC}}$$

Current amplitude is sharper for R2 than R1.

Q or quality factor is a measure of the sharpness of the resonance peak. Numerically, it is given as

$$Q = \frac{\omega_0}{2\Delta\omega} = \frac{\omega_0 L}{R}$$

Significance of Q factor:

Smaller is the 'bandwidth' $\Delta\omega$, larger is Q factor.

25.

According to Bohr's postulates, in a hydrogen atom, a single electron revolves around a nucleus of charge $+e$. For an electron moving with a uniform speed in a circular orbit of a given radius, the centripetal force is provided by Coulomb force of attraction between the electron and the nucleus. The gravitational attraction may be neglected as the mass of electron and proton is very small.

So,

$$\frac{mv^2}{r} = \frac{ke^2}{r^2}$$

$$\text{or } mv^2 = \frac{ke^2}{r} \dots\dots\dots(1)$$

where m = mass of electron
 r = radius of electronic orbit
 v = velocity of electron.

Again,

$$mvr = \frac{nh}{2\pi}$$

$$\text{or } v = \frac{nh}{2\pi mr}$$

From eq.(1), we get,

$$m \left(\frac{nh}{2\pi mr} \right)^2 = \frac{ke^2}{r}$$

$$r = \frac{n^2 h^2}{4\pi^2 k m e^2} \dots \dots \dots (2)$$

(i) For finding Kinetic energy of electrons:

Using eq (2), we get

$$E_K = \frac{ke^2}{2} \times \frac{4\pi^2 k m e^2}{n^2 h^2}$$

$$= \frac{2\pi^2 k^2 m e^4}{n^2 h^2}$$

(ii) Potential energy

$$E_P = -\frac{k(e) \times (e)}{r} = -\frac{ke^2}{r}$$

Using eq (2), we get

$$E_P = -ke^2 \times \frac{4\pi^2 k m e^2}{n^2 h^2}$$

$$= -\frac{4\pi^2 k^2 m e^4}{n^2 h^2}$$

Hence, total energy of the electron in the n^{th} orbit

$$E = E_P + E_K = -\frac{4\pi^2 k^2 m e^4}{n^2 h^2} + \frac{2\pi^2 k^2 m e^4}{n^2 h^2} = -\frac{2\pi^2 k^2 m e^4}{n^2 h^2} = -\frac{13.6}{n^2} \text{ eV}$$

(b) the negative binding energy corresponds to the fact :stability.

(c)

When an electron jumps from any of the higher states to the state with $n = 3$ (IIIrd state), the series of spectral lines emitted lies in near infra-red region and are called as Paschen Series. The wave number of any spectral line can be given by using the relation:

$$\nu = RZ^2 \left(\frac{1}{3^2} - \frac{1}{n_2^2} \right) \quad n_2 = 4, 5, 6, 7, \dots$$

Series limit (for H - atom) : $\infty \rightarrow 3$ i.e. $\nu = R/9$

α line : $4 \rightarrow 3$; β line : $5 \rightarrow 3$; γ line : $6 \rightarrow 3$

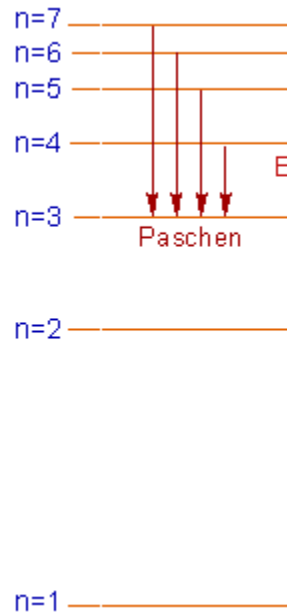

26. (a) Because the car acts like electric shield. We know that the electric field inside the closed conductor is zero.
(b) Awareness and humanity or concern.
(c) Gratitude and obligation.

I was struck in severe thunder storm once in an isolated place. I insisted to go out of the car and enjoy the rain. My parents advised not to go out of the car otherwise I may get thunderstruck.

27.

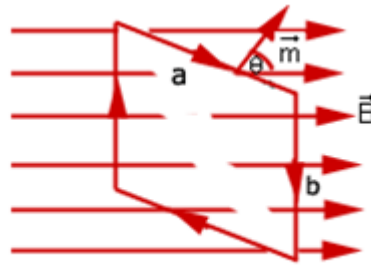

Let the loop be so oriented that its magnetic moment vector \vec{m} makes an angle θ with the uniform magnetic field \vec{B}

(a) Force acting on the loop

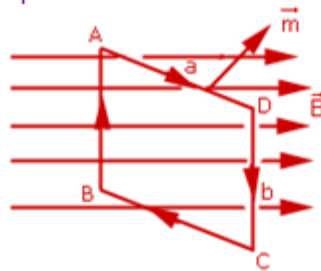

Consider sides AD and BC. The currents in them have opposite directions.

Force on side AD is

$$\vec{F}_{AD} = I \int_{AD} d\vec{l} \times \vec{B}$$

Now, \vec{B} is constant and $\int d\vec{l}$ is just the sum of infinitesimal length vectors along AD in the direction of current flow.

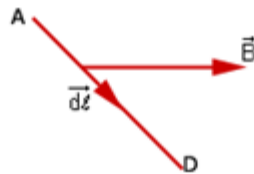

$$\therefore \int_{AD} d\vec{l} = \vec{AD}$$

where \vec{AD} is a vector of magnitude a and direction from A to D.

$$\therefore \vec{F}_{AD} = I \vec{AD} \times \vec{B}$$

Similarly,

$$\vec{F}_{BC} = I \vec{CB} \times \vec{B}$$

$$\therefore \vec{F}_{AD} + \vec{F}_{BC} = I (\vec{AD} + \vec{CB}) \times \vec{B}$$

$$\vec{AD} + \vec{CB} = 0,$$

since they are equal and opposite vectors.

Similarly, forces on sides AB and DC cancel. So total force $\vec{F} = 0$ on the loop.

Torque acting on the loop;

We explicitly look at forces acting on sides of the loop.

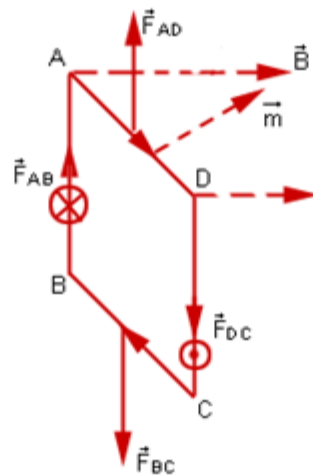

$$\vec{F}_{AD} = I\vec{AD} \times \vec{B}$$

$$\vec{F}_{DC} = I\vec{DC} \times \vec{B}$$

$$\vec{F}_{BC} = I\vec{BC} \times \vec{B}$$

$$\vec{F}_{AB} = I\vec{BA} \times \vec{B}$$

As shown above, even though these forces cancel, \vec{F}_{DC} and \vec{F}_{AB} form a couple, which tends to rotate the loop so that it tends to align perpendicular to \vec{B} (i.e. \vec{m} parallel to \vec{B}) \vec{F}_{DC} comes out of the plane of the page and \vec{F}_{AB} is into the plane of the page.

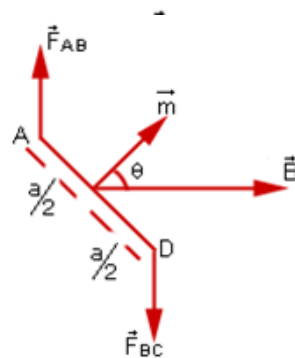

Looking down from side AD, the magnitude of the torque about the axis of the loop is

$$\begin{aligned} \left[|\vec{F}_{AB}| \frac{a}{2} + |\vec{F}_{BC}| \frac{a}{2} \right] \sin\theta &= IBb \left(\frac{a}{2} + \frac{a}{2} \right) \sin\theta \\ &= I(ab)B \sin\theta \\ &= IBA \sin\theta \\ &= (B)(IA \sin\theta) \end{aligned}$$

where $A = ab$ is area of the loop. Direction of the torque is normal to both \vec{m} and \vec{B} .

$$\therefore \text{Torque } \vec{\tau} = I\vec{A} \times \vec{B} = \vec{m} \times \vec{B}$$

(b)

We know, Lorentz force, $F = Bqv \sin\theta$
 $= 90^\circ$

So, Lorentz force, $F = Bqv$

Thus the particles will move in circular path.

$$Bqv = \frac{mv^2}{r} \Rightarrow r = \frac{mv}{Bq}$$

A proton is a positively charged particle. So it will execute a circular trajectory.

Deuteron is uncharged particle. So it will not be deflected in the magnetic field.

OR

The torque on the needle is $\tau = m \times B$

In magnitude $\tau = mB \sin\theta$

Here τ is restoring torque and θ is the angle between m and B

Therefore, in equilibrium $I \frac{d^2\theta}{dt^2} = -mB \sin\theta$

Negative sign with $mB \sin\theta$ implies that restoring torque is in opposition to deflecting torque. For small value of θ in radians, we approximate $\sin\theta = \theta$ and

get $I \frac{d^2\theta}{dt^2} = -mB \theta$

So $\frac{d\theta}{dt} = -\frac{mB}{I} \theta$

$$T = 2\pi \sqrt{\frac{I}{mB}}$$

(b)

As, Horizontal component of earth's magnetic field, $B_H = B \cos\delta$

Putting $\delta = 90^\circ$

$$\therefore B_H = 0$$

For a compass needle align vertical at a certain place, angle of dip,

$$\delta = 90^\circ$$

28. (a)

A simple microscope has limited magnification, so one uses a compound microscope, in which there are two lenses, one compounding the magnification due to the other. The lens nearest the object, called the objective, forms a real, inverted and magnified image of the object, which serves as the object for the eyepiece lens. The first inverted image is near the focal point of the eye-piece, at a distance appropriate for image formation at infinity.

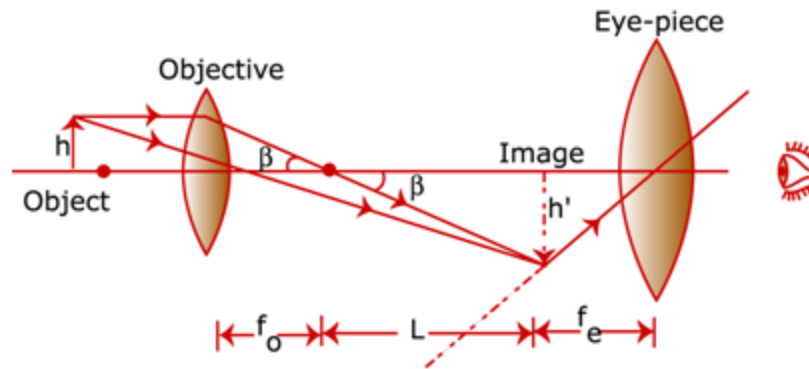

The diagram above shows that the magnification is

$$m_o = \frac{h'}{h} = \frac{L}{f_o}$$

where h' is the size of the first image, the object size being h and the object focal length f_o . Since the inverted first image is at the focal point of the eye piece, the angular magnification is

$$m_e = \frac{D}{f_e}$$

Therefore, the total magnification is

$$m = m_o m_e = \left(\frac{L}{f_o}\right) \left(\frac{D}{f_e}\right)$$

(b)

Differences between myopia and hyper metropia :

For myopia:

- i. The power of the eye is too great and focal length is small
- ii. Excessive curvature of the cornea.
- iii. Eyeball is elongated.

For hypermetropia:

- This defect is caused due to:
- i. Focal length of the eye lens is too great.
 - ii. Eyeball is too short.
 - iii. Small curvature of the cornea.

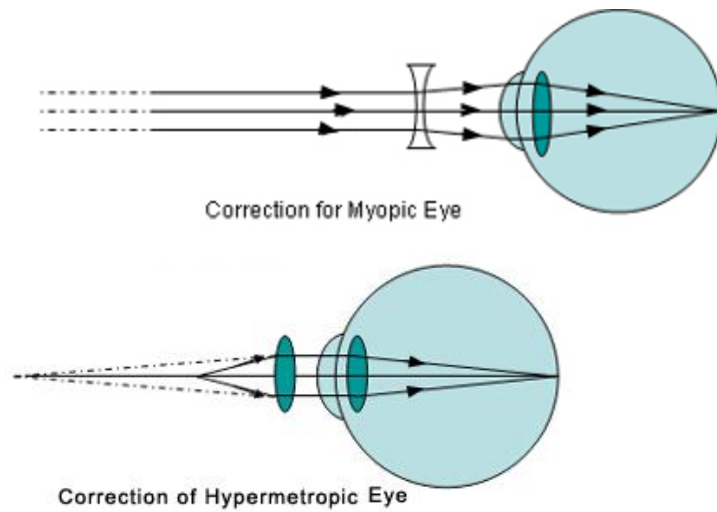

OR

(a)

To understand laws of reflection and refraction, consider the following construction

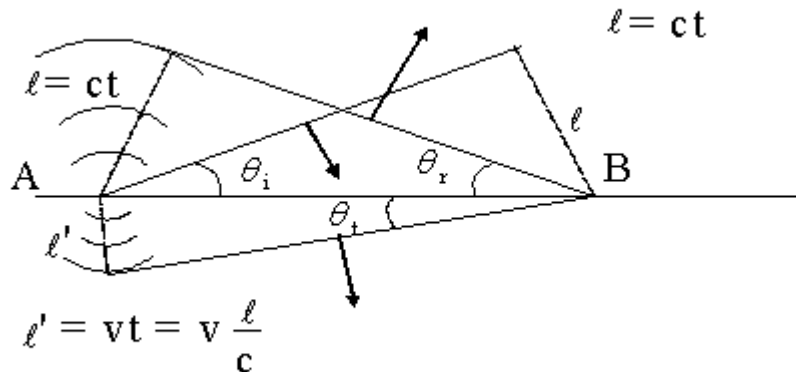

The figure above shows an incident plane wavefront, whose surface makes an angle θ_i with the boundary separating two media, the speed of light being c in the first medium, and v in the second medium. Consider the point A of this wavefront, which is in contact with the surface. This will give rise to secondary wavelets, which emanate spherically, and move with *different* speeds in the two media. In the time $t = \frac{l}{c}$ that it takes the wavefront to reach point B, the waves travel the same distance l in the first medium, but a *shorter* distance (assuming the refractive index of the second medium is more than the first, that is, $v < c$) $l' = \frac{v}{c}l$ in the second medium. These waves emanating from A and B (when the wavefront reaches it) and other points (as they reach the surface of the boundary) form *two* envelopes, one in the first medium and the other in the *second* medium. Since they travel with the same speed in the first medium, the figure clearly shows that the envelope formed by the wavelets in this medium, is obtained by drawing a tangent from point B to the surface of the sphere with centre at A and radius l is such that it is at an angle $\theta_r = \theta_i$. Since the wave travels a *shorter* distance l' in the second medium, the wavefront in this medium, again formed by drawing a tangent from B to sphere of radius l' and with A as centre, is *bent* with respect to the first wavefront, making an angle $\theta_r \neq \theta_i$.

It is clear that

$$\begin{aligned}\sin \theta &= \frac{\ell}{AB} \\ \sin \theta &= \frac{\ell'}{AB} \\ \Rightarrow \frac{\sin \theta}{\sin \theta} &= \frac{\ell}{\ell'} = \frac{c}{v} = \frac{n_2}{n_1}\end{aligned}$$

where n_1 and n_2 are refractive indices of the first and the second media respectively. In particular, if the first medium is vacuum $n_1 = 1, c = 3 \times 10^8 \text{ m/s}$. So, we get Snell's laws of reflection and refraction, using Huygen's principle.

- (b) i. Frequency of reflected and refracted light will be the same.
ii. No the energy remains the same. As the speed decreases wavelength also decreases so the frequency remains same. Energy of light wave = $h \times \text{frequency}$
 $h = \text{Planck's constant}$

29. (a)

It is an instrument identical to the meter bridge except that in this case, the resistance wire is of more than a metre in length. This enables greater accuracy. A standard cell of emf ϵ_1 maintains a constant current through the wire. The wire has a uniform resistance per unit length. The potential gradient ρ depends on the current in the wire. If an emf ϵ_1 is balanced against length ℓ_1 .

$$\epsilon_1 = \rho \ell_1$$

Similarly, if ϵ_2 is balanced against ℓ_2 ,

$$\epsilon_2 = \rho \ell_2$$

$$\therefore \frac{\epsilon_1}{\epsilon_2} = \frac{l_1}{l_2}$$

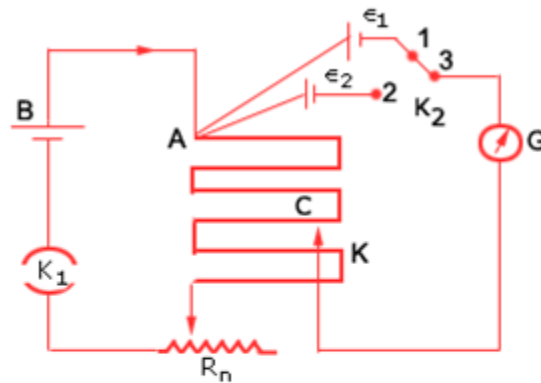

By means of a battery B and Rheostat R_n a steady current is passed through wire AC. Two cells ϵ_1 and ϵ_2 are put in such a way that positive terminals are connected to A and negative terminal to galvanometer through a 2-way plug key k.

First, ϵ_1 is connected by connecting 1 and 3 points of K_2 and by moving the jockey k on the potentiometer wire, the null point is obtained. If the balancing length is l_1 , then

$$\epsilon_1 = \rho l_1$$

After this, points 2 and 3 of K_2 are connected.

i.e., ϵ_2 is put into the circuit and once again, corresponding to the null point

$$\epsilon_2 = \rho l_2$$

$$\therefore \frac{\epsilon_1}{\epsilon_2} = \frac{l_1}{l_2}$$

(b)

- (i) The emf of the cell connected in main circuit may not be more than the emf of the primary cells whose emfs are to be compared.
- (ii) The positive ends of all cells are not connected to the same end of the wire.

OR

(a) Kirchhoff's First Law – Junction Rule

The algebraic sum of the currents meeting at a point in an electrical circuit is always zero.

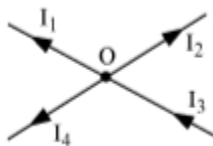

Let the currents be I_1 , I_2 , I_3 and I_4 .

Convention:

Current towards the junction – positive

Current away from the junction – negative

Kirchhoff's Second Law – Loop Rule

In a closed loop, the algebraic sum of the *emfs* is equal to the algebraic sum of the products of the resistances and current flowing through them.

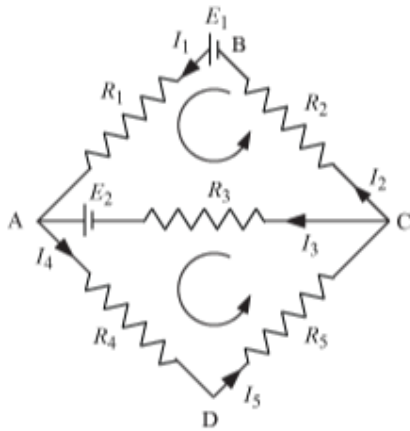

For closed part BACB, $E_1 - E_2 = I_1 R_1 + I_2 R_2 - I_3 R_3$

For closed part CADC, $E_2 = I_3 R_3 + I_4 R_4 + I_5 R_5$

Wheatstone Bridge:

The Wheatstone Bridge is an arrangement of four resistances as shown in the following figure.

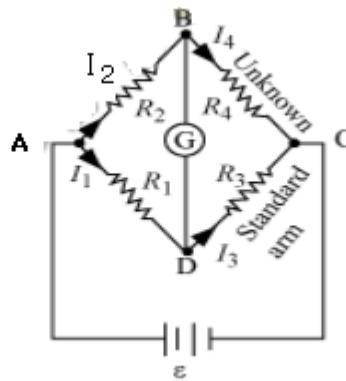

R_1 , R_2 , R_3 , and R_4 are the four resistances.

Galvanometer (G) has a current I_g flowing through it at balanced condition,

$$I_g = 0$$

Applying junction rule at B,

$$\therefore I_2 = I_4$$

Applying junction rule at D,

$$\therefore I_1 = I_3$$

Applying loop rule to closed loop ADBA,

$$-I_1 R_1 + 0 + I_2 R_2 = 0$$

$$\therefore \frac{I_1}{I_2} = \frac{R_2}{R_1} \quad \dots(1)$$

Applying loop rule to closed loop CBDC,

$$I_2 R_4 + 0 - I_1 R_3 = 0 \quad \because I_3 = I_1, I_4 = I_2$$

$$\therefore \frac{I_1}{I_2} = \frac{R_4}{R_3} \quad \dots(2)$$

From equations (1) and (2),

$$\frac{R_2}{R_1} = \frac{R_4}{R_3}$$

This is the required balanced condition of Wheatstone Bridge.

(b)

$$\frac{R_1}{R_2} = \frac{40}{60}$$

$$\Rightarrow R_2 = \frac{3}{2} R_1$$

$$\frac{R_1 + 10}{R_2} = \frac{60}{40}$$

$$\frac{R_1 + 10}{\frac{3}{2} R_1} = \frac{60}{40} = \frac{3}{2}$$

$$2R_1 + 20 = \frac{9}{2} R_1$$

$$4R_1 + 40 = 9R_1$$

$$5R_1 = 40$$

$$R_1 = 8\Omega$$

$$R_2 = \frac{3}{2} \times 8 = 12\Omega$$